

Specifications

Output Power HP (kW)	20 (15)
Phase	3 Phase
Pole	2 Pole
Frame Number	160M

Degrees of Protection	IP 55
Enclosure Construction	Totally-enclosed Fan-cooled
Thermal Class	Class F (155 °C)

Alignment	Vertical
Frame Material	Steel plate

Power Transmission	Direct-couple or Belt Driven
Direction of Rotation	Counterclockwise (CCW) viewed from shaft-end side



Connection Type	Terminal Block (6 Leads)
Coating Colour	Munsell N5.5 (Gray)
Conformed Standard	IEC 60034-1 & JEC-2137-2000



Voltage & Frequency	HT Type
	380~415V 50Hz 380~440V 60Hz (suitable for γ - Δ starting)

Dimensions (mm)

Flange Number	Motor								
	D	IE	LA	LB	LC	LE	LG	LL	LZ
FF300	324	213	300	250 j6	350	5	20	500	18.5

Terminal Box			Shaft End						
KD	KG	KL	LR	Q	QK	S	T	U	W
PF 1 1/4	147	259	110	110	90	42 k6	8	5	12

Bearing No.		Approximated Weight (kg)	Approximated Packing Dimensions (LxWxH)	Gross Weight (kg)
Drive End	Opposite			
6309ZZ	6308ZZ	120	778 x 602 x 557	144

Connection & Connection Diagram

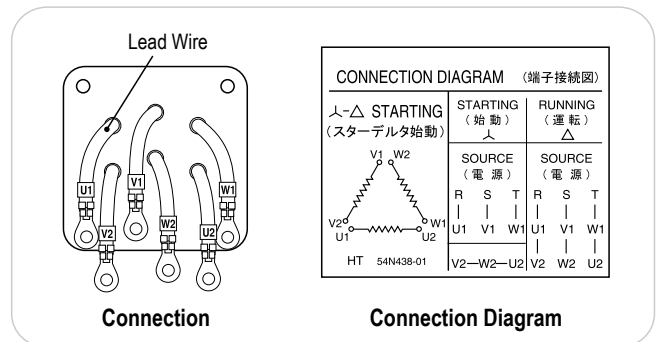

Circumstance Conditions

Ambient Temperature	-20 ~ +40°C
Ambient Humidity	95% RH or less
Operating Altitude	Less than 1,000m above sea level
Environment	No bursting / erosive gas or vapor

Motor Characteristics

Type	Hz	V	50% Load			75% Load			100% Load				Torque(%)		Is (A)	Inertia GD ² (kg-m ²)	
			(A)	Eff(%)	PF(%)	(A)	Eff(%)	PF(%)	(A)	Eff(%)	PF(%)	Speed (r/min)	Torque (kg-m)	Ts			Tm
HT	50	380	15.3	0.93	0.80	21.0	0.94	0.87	27.1	0.93	0.90	2910	5.02	226	304	200	0.176
		415	16.2	0.91	0.71	20.9	0.92	0.81	26.2	0.93	0.86	2920	5.00	271	361	219	
	60	380	14.2	0.92	0.87	20.2	0.92	0.92	26.6	0.92	0.93	3490	4.19	183	265	167	
		440	13.6	0.92	0.79	18.3	0.93	0.87	23.5	0.93	0.90	3510	4.16	147	356	193	